

Long Edge Chamfer Mill Request Form

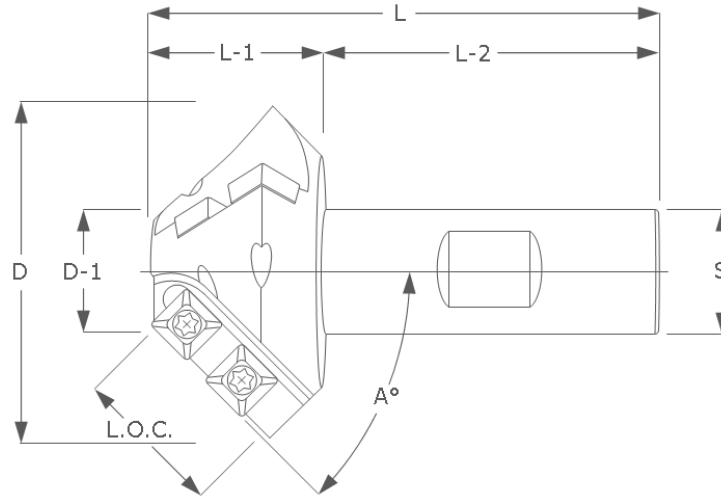

Tool Info	
D	
D-1	
L.O.C.	
A°	
L	
L-1	
L-2	
S	
Plunging or Milling	
Coolant Thru? Yes	No

Flat Style (Select One)	
Weldon (Shown)	
Tapered	
Straight	
None	

Mill Info	
Vertical	
Horizontal	
Spindle Taper	
Horsepower	
Coolant PSI	

Material Info	
Material	
Hardness	
Additional Info	

Lathe Info	
Chuck	
Collet	
Horsepower	
Coolant PSI	

Distributor Info		
Company	Company Name	Branch
Salesperson	Primary	Inside Salesperson (Optional)
E-mail		
Phone #		

Note: We work on requests in the order we receive them. We will contact you with any questions.

End-User Info	
Company	
Contact Person	
E-mail	
Phone #	

Additional Info

Attention To avoid delays in the quoting process, please have the request form filled out as complete and accurately as possible before submitting to K-Tool, Inc. End-users may fill out & submit this form directly to K-Tool, Inc if the distributor information is provided above. If you do not have a K-Tool, Inc. distributor you are welcome to call us and we will find one in your area.