



METER LOOP

AND

WIRING SPECIFICATIONS

Version 2025.9

HILCO ELECTRIC COOPERATIVE, INC.
METER LOOP AND WIRING SPECIFICATIONS

** The following meter loop and wiring specifications are intended for residential and ** small non-residential services. Where service requirements exceed single phase 120/240 voltage and/or 320 amps, please contact HILCO Electric Cooperative for any adjustments and additional requirements.

****WARNING****

PLEASE CALL FOR UTILITY LOCATES BEFORE DIGGING

AT 1-800-DIGTESS or 811

HILCO Electric Cooperative shall require that the following conditions be met before electric service will be provided:

1. The consumer is responsible for installing and maintaining the electrical facilities in accordance with HILCO requirements.
2. The consumer may not contact, attach or utilize HILCO's electric distribution facilities.
3. HILCO reserves the right to approve a consumer's complete electric system and to determine that all conditions of code, safety and the design of the facilities being served have no detrimental effects upon the utility service. **Where HILCO specifications exceed code they shall take precedence.**
4. Consumers will furnish the meter base, meter loop, and service entrance facilities. Poles and/or any material used for meter loops shall be the consumer's responsibility.
5. Poles and/or any material used for meter loops shall be made of sound material and appropriately treated to resist degradation from the environment. HILCO will not connect service to any type of pole that has been spliced or pieced together. (Refer to the appropriate specification for installation and size requirements.)
6. Temporary meter loops are the consumer's responsibility and are meant to be temporary installations used during construction. Temporary meter loops shall be a minimum distance from HILCO's overhead facilities and shall not exceed ninety feet (90'). For underground installations, temporary poles shall not exceed ten feet (10') from HILCO's underground facilities.
7. The consumer shall install the appropriate contact apparatus to accept HILCO's electric service. All mast risers (through the roof) shall be 2" galvanized rigid metal conduit (as a minimum) and of sufficient strength to support the service drop conductors.
8. All service contacts shall not be less than thirteen (13') feet from final grade and all weather heads shall not be less than twelve and a half (12' 6") feet from final grade. **HILCO Electric enforces the National Electric Safety Code Section 23 Rule 232 and takes precedence over this rule to ensure that adequate clearances are met and maintained.**

9. The meter base shall normally be the socket type, shall be located outside of buildings, must be able to accept a padlock by HILCO and shall be accessible to HILCO employees at all times.
10. HILCO Electric's specifications do not allow "double lugging" or the installation of multiple conductors under one lug inside the meter base. Specific meter bases may accept multiple conductors, if it has the ability to exchange the lugs to accommodate and also if space permits within the meter base.
11. The meter loop will consist of three INSULATED COPPER or ALUMINUM wires, 100-amp capacity as a minimum for residential service and 60-amp capacity as a minimum for non-residential service. The neutral, as a minimum, can not be smaller than two sizes below the conductor size.
12. Wire size shall be based according to load, amp rating of main disconnect and rating of meter base. To ensure proper coordination, the amp rating of wire should be equal to or greater than the main disconnect and the main disconnect shall not exceed the amp rating of the meter base.
 - a. The main disconnect shall have a rating not less than the calculated load to be carried.
 - b. Every service shall have a main disconnect. The NEC Article 230.71, changed in 2020, and **does not** allow a maximum of six breakers to be grouped in the place of a main disconnect.
13. HILCO **will not** attach their electric service directly to any type of portable or mobile structure.
14. HILCO **will** attach their electric service directly to a manufactured home or structure, provided that any axles and tongue/hitches be removed, it is mounted on a permanent, poured-in-place, concrete foundation and/or piers.
15. Where service is supplied by more than one electric service to a single structure, a permanent plaque must be installed containing information describing all other electric services, their location and the area they serve.
16. Service equipment disconnecting means or main breaker shall be provided and installed by the consumer. It's purpose shall be to provide disconnection of all conductors in a building or other structure from the service-entrance conductors. The NEC Code gives note, in Article 230.70, that the location of the disconnecting means shall be "readily accessible" and gives HILCO, as the electric provider, the authority to enforce this location.
 - a. HILCO Electric takes precedence over this Article 230.70 and states that all service equipment disconnecting means shall be installed within a distance of eight circuit feet from the service entrance.
 - b. If the distance of eight circuit feet can not be met, then either an outside main disconnect needs to be installed or a readily accessible location needs to be used.

Allowable ampacities for residential dwellings and other non-residential applications. NEC Code gives note, in Article 310.12, that residential dwellings shall have a minimum 100 amp and all other non-residential, in Article 230.79 (D), shall have a minimum 60 amp utilizing the below wire ampacity tables:

<u>Copper</u> Wire (THW) Size and Ampacity	Residential		Non-Residential	
	NEC	Table 310.12 Residential Service Entrance	NEC	Table 310.16 Non-Residential Service Entrance
# 6		-		65 amps
# 4		100 amps		85 amps
# 3		110 amps		100 amps
# 2		125 amps		115 amps
# 1		150 amps		130 amps
# 1/0		175 amps		150 amps
# 2/0		200 amps		175 amps
# 3/0		225 amps		200 amps
# 4/0		250 amps		230 amps
# 250		300 amps		255 amps
# 300		-		285 amps
# 350		350 amps		310 amps
# 400		400 amps		335 amps

<u>Aluminum or Copper-Clad Aluminum</u> Wire (THW) Size and Ampacity	NEC		NEC	
		Table 310.12 Residential Service-Entrance		Table 310.16 Non-Residential Service Entrance
# 4		-		65 amps
# 3		-		75 amps
# 2		100 amps		90 amps
# 1		110 amps		100 amps
# 1/0		125 amps		120 amps
# 2/0		150 amps		135 amps
# 3/0		175 amps		155 amps
# 4/0		200 amps		180 amps
# 250		225 amps		205 amps
# 300		250 amps		230 amps
# 350		300 amps		250 amps
# 500		350 amps		270 amps
# 600		400 amps		310 amps

HILCO ELECTRIC COOPERATIVE, INC.
TEMPORARY METER INSTALLATION-OVERHEAD SERVICE

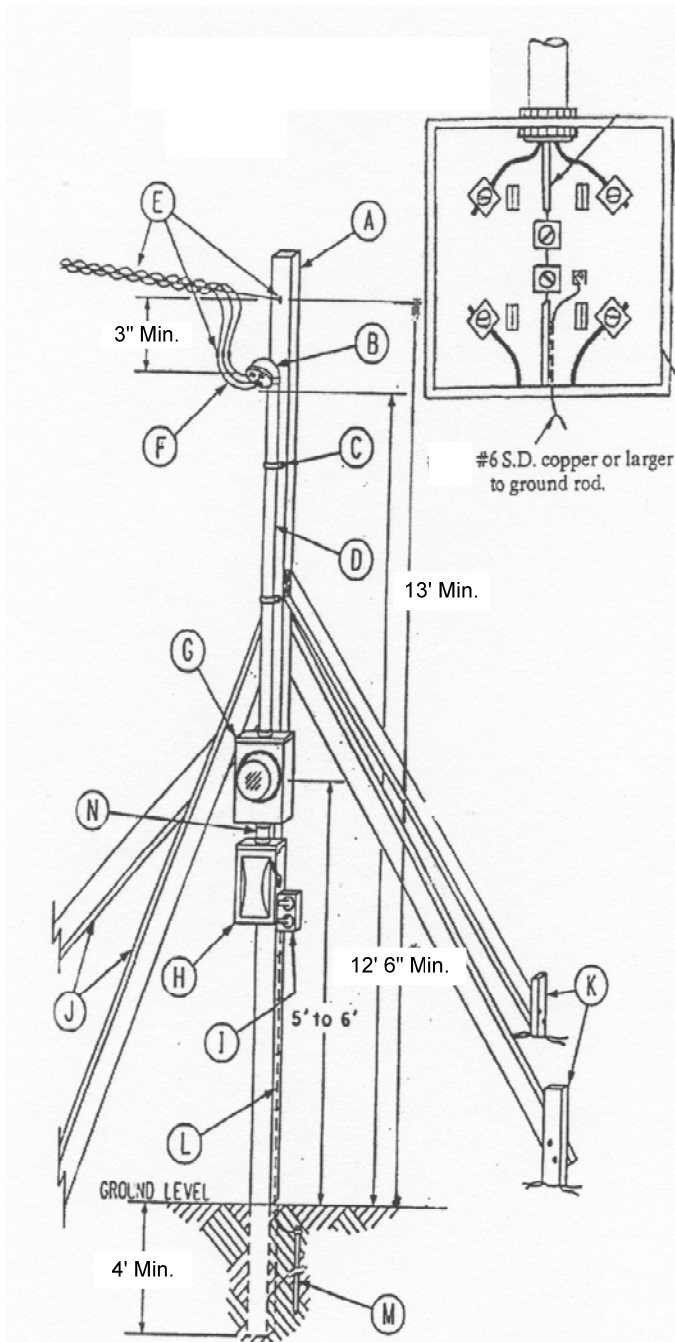

A - 4" X 4" X 17' WOODEN MAST MINIMUM.

B - DO NOT EXTEND WEATHERHEAD ABOVE TOP OF POLE. MUST BE MINIMUM 3" BELOW TOP OF POLE. (MINIMUM HEIGHT OF 12' 6" FROM FINAL GRADE)

C - METAL 2-HOLE CONDUIT STRAP SEPARATION SHALL BE NO GREATER THAN 30" WITH A MINIMUM OF 2 CONDUIT STRAPS.

D - SERVICE RISER SHALL BE FURNISHED AND INSTALLED BY CONSUMER. RISER SHALL BE GALVANIZED RIGID STEEL, I.M.C. OR SCH 80 ELECTRICAL PVC. (1 1/4" MIN)

E - SERVICE DROP CONDUCTORS, SERVICE ATTACHMENTS, AND CONNECTORS FURNISHED AND INSTALLED BY HILCO. (MINIMUM HEIGHT OF 13' FROM FINAL GRADE)

F - A MINIMUM OF 2' OF CONDUCTOR SHALL EXTEND FROM WEATHERHEAD TO FORM DRIP LOOP. CONSUMER SHALL MARK NEUTRAL WITH WHITE TAPE.

G - METER BASE FURNISHED, INSTALLED, AND WIRED BY CONSUMER. (MINIMUM 5' TO 6' FROM GRADE)

H - WEATHERPROOF BOX, WITH MAIN DISCONNECT. FURNISHED AND INSTALLED BY CONSUMER. (AMP RATING SHALL BE CONSISTANT WITH SERVICE CONDUCTOR AMPACITY)

I - ANY WEATHERPROOF RECEPTACLES SHALL HAVE GROUND FAULT PROTECTION.

J - 2" X 4" BRACES ATTACHED WITH LUG SCREWS OR 16 PENNY NAILS AT 90 FROM EACH OTHER. (FACED TOWARDS HILCO'S FACILITY)

K - 2" X 4" STAKES.

L - COPPER GROUNDING ELECTRODE CONDUCTOR SIZED AND INSTALLED BY CONSUMER ACCORDING TO HILCO REQUIREMENTS. (#6 SOFT DRAWN BARE OR STRANDED COPPER MINIMUM.)

M - APPROVED GROUNDING ELECTRODE AND CLAMP, FURNISHED AND INSTALLED BY CONSUMER. (GROUND ROD SHALL BE 5/8" X 8' COPPER OR GALVANIZED.)

N - NIPPLE RACEWAY TO METER SOCKET SHALL BE RIGID METAL, I.M.C. OR SCH 80 ELECTRICAL PVC.

**** Minimum 10' and Maximum 90' from **
HILCO's Facilities**

NOTE: CUSTOMER SHALL INSTALL AND MAINTAIN THIS FACILITY IN A SAFE CONDITION. IT CAN BE LEFT INTACT AND MOVED FROM JOB SITE TO JOB SITE. IT SHALL NOT BE MOVED WHILE ENERGIZED. INTENDED FOR TEMPORARY USE ONLY.

**HILCO ELECTRIC COOPERATIVE, INC.
UNDERGROUND HOUSE METER SERVICE**

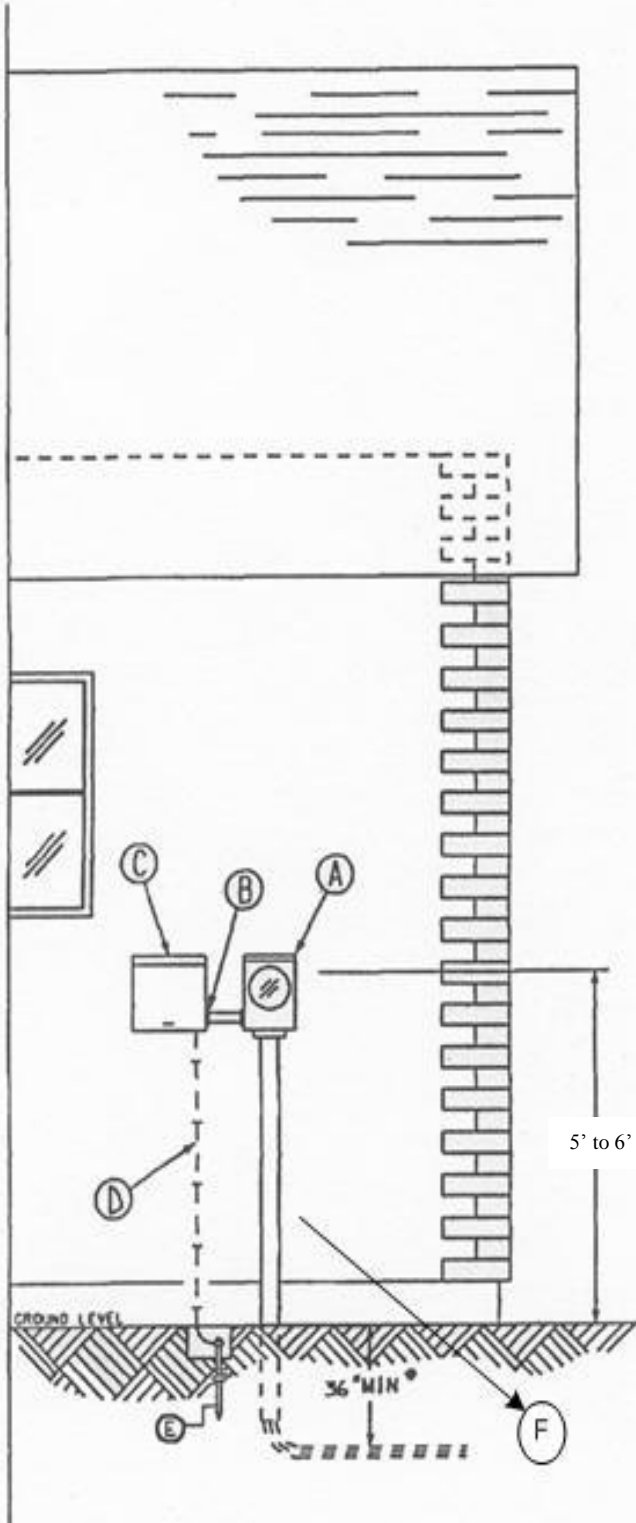

A - METER BASE FURNISHED, INSTALLED AND WIRED BY CONSUMER.

B - ALL CONDUIT NIPPLE RACEWAYS SHALL BE RIGID METAL, I.M.C. OR SCH 80 ELECTRICAL PVC.

C - WEATHERPROOF BOX, WITH MAIN DISCONNECT. FURNISHED AND INSTALLED BY! CONSUMER. THE ENCLOSURE SHALL BE WITHIN 8 CIRCUIT FEET OF THE METER (AMP RATING SHALL BE CONSISTANT WITH SERVICE CONDUCTOR AMPACITY)

D - COPPER GROUNDING ELECTRODE CONDUCTOR SIZED AND INSTALLED BY CONSUMER ACCORDING TO HILCO REQUIREMENTS. (#6 SOFT DRAWN BARE OR STRANDED COPPER MINIMUM.)

E - APPROVED GROUNDING ELECTRODE AND CLAMP, FURNISHED AND INSTALLED OUTSIDE THE STRUCTURE BY THE CONSUMER. (GROUND ROD SHALL BE 5/8" X 8' COPPER OR GALVANIZED.)

F - CONDUIT, WIRE, AND TRENCH INSTALLED BY HILCO ELECTRIC. CONDUIT RISER SHALL HAVE NO OBSTRUCTIONS OR BENDS GOING INTO THE METER BASE. ENTIRE CONDUIT RISER SHALL BE VISIBLE AND REMAIN ON THE OUTSIDE OF THE STRUCTURE.

WIRING DIAGRAM OF INSIDE UNDERGROUND METER BASE

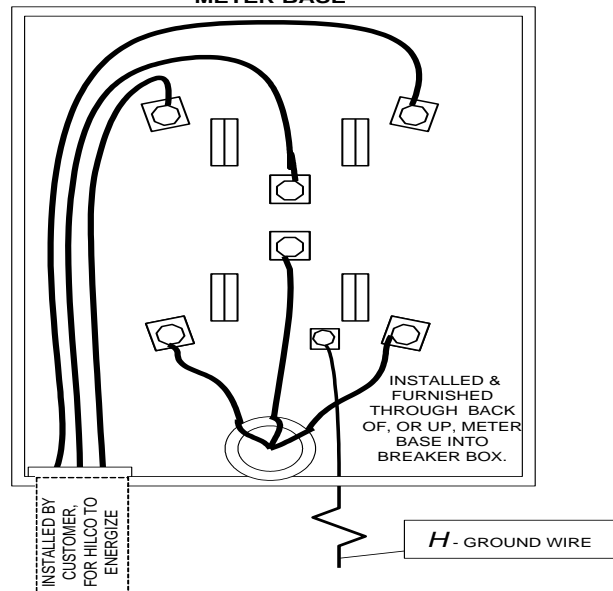

HILCO ELECTRIC COOPERATIVE, INC.

PERMANENT UNDERGROUND METER POLE (OPTION #2)

WIRING DIAGRAM OF INSIDE UNDERGROUND METER BASE

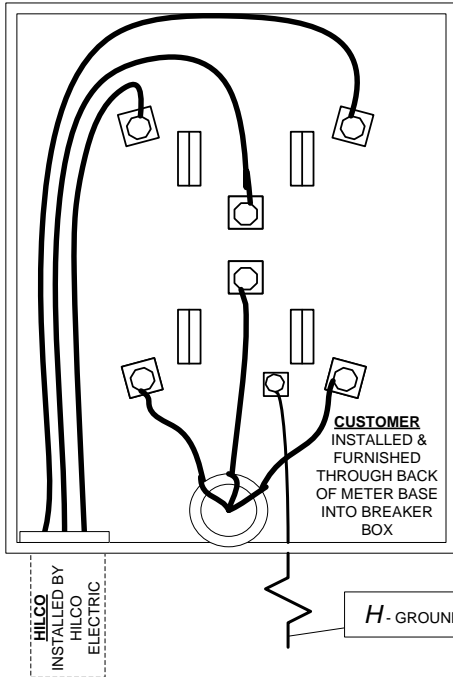

*** WARNING *** PLEASE CALL FOR UTILITY LOCATES BEFORE *** WARNING ***

DIGGING NEAR UNDERGROUND ELECTRIC FACILITY'S

1 - 800 - DIGTESS

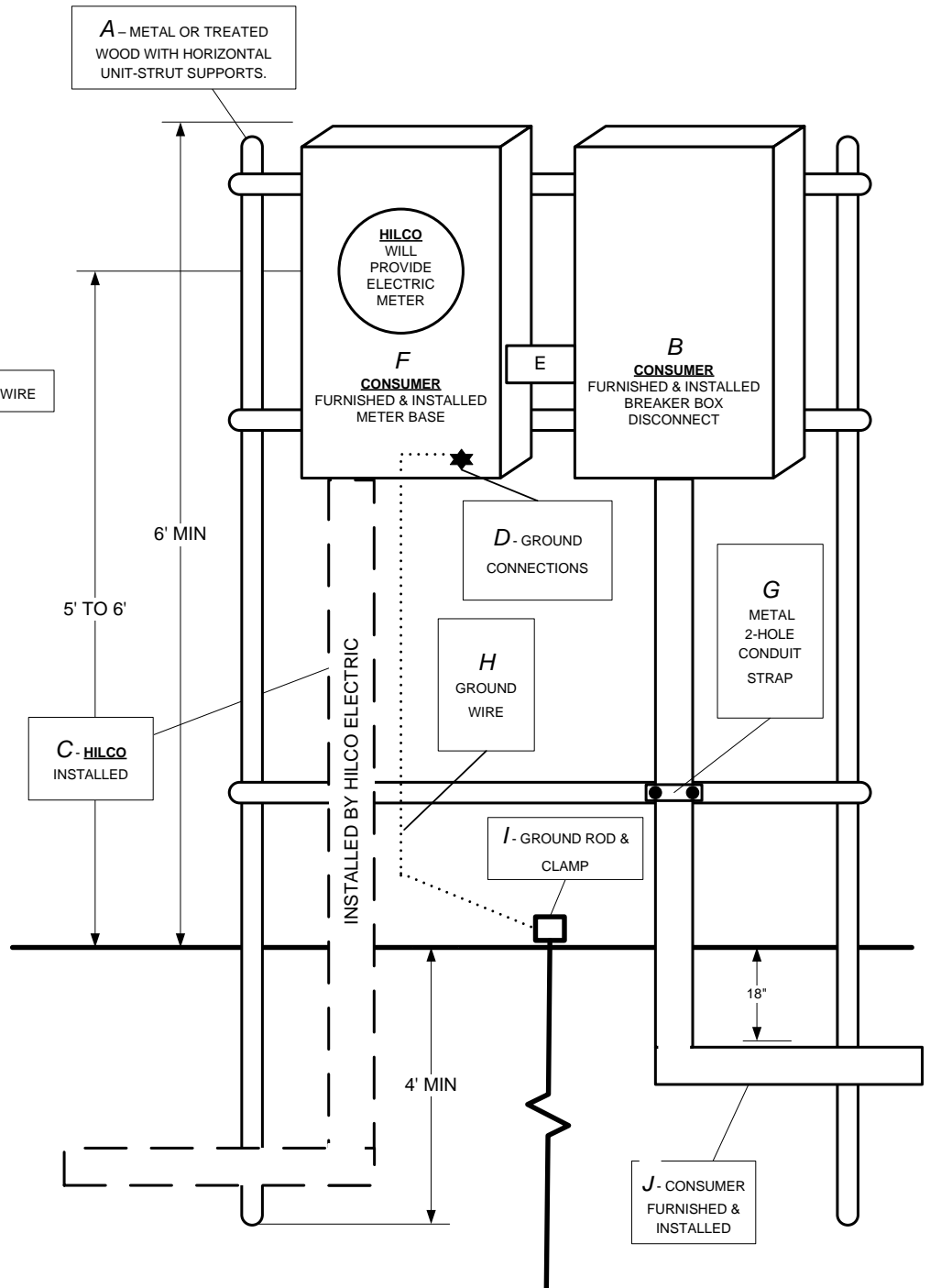

A - MADE OF STABLE METAL MATERIAL OR TREATED WOOD WITH HORIZONTAL UNIT-STRUT SUPPORTS.

B - WEATHERPROOF BOX ; 7
0\$1 '6&211(&7)851,6# \$'
.16\$(' %7 &21680(5
03 5\$1* 6# %
&216,6717 ;7 6(59&
&21'8&25 0&,7

C - ELECTRIC METER, CONDUIT, WIRE, AND TRENCH INSTALLED BY HILCO ELECTRIC.

D - GROUNDING ELECTRODE CONDUCTOR ENTERS AND IS CONNECTED TO METER BASE.

E - NIPPLE RACEWAY TO METER SOCKET SHALL BE RIGID METAL, I.M.C. OR SCH 80 ELECTRICAL PVC.

F - METER BASE FURNISHED, INSTALLED, AND WIRED BY CONSUMER.

G - METAL 2-HOLE CONDUIT STRAP.

H - COPPER GROUNDING ELECTRODE CONDUCTOR SIZED AND INSTALLED BY CONSUMER ACCORDING TO HILCO REQUIREMENTS. (#6 SOFT DRAWN BARE OR STRANDED COPPER MINIMUM.)

I - APPROVED GROUNDING ELECTRODE AND CLAMP, FURNISHED AND INSTALLED BY CONSUMER. (GROUNDING ROD SHALL BE 5/8" X 8' COPPER OR GALVANIZED.)

J - SERVICE RACEWAY SHALL BE GALVANIZED RIGID STEEL CONDUIT, I.M.C. OR SCH 80 ELECTRICAL PVC. FURNISHED AND INSTALLED BY CONSUMER TO A MINIMUM DEPTH OF 18 INCHES BELOW GROUND LEVEL.