



Whitney Office
 4581 FM 933- PO Box 2480
 Whitney TX 76692-5480
 Tel: 254-694-5237 Fax: 254-694-4062
 Toll Free: 888-850-6551

Midlothian Office
 300A Silken Crossing
 Midlothian, TX 76065
 Tel: 972-723-2900 Fax: 972-723-2911

Serving our Members with Pride since 1937

Elm Mott Office
 298 S Connally Dr
 Elm Mott, TX 76640
 Tel: 254-687-2331
 Toll Free: 800-338-6425

Itasca Office
 115 East Main St- PO Box 127
 Itasca, TX 76055
 Tel: 254-687-2331 Fax: 254-687-2428
 Toll Free: 800-338-6425

NEW CONSTRUCTION TYPE	
Please choose one:	
<input type="checkbox"/>	RESIDENTIAL
<input type="checkbox"/>	NON RESIDENTIAL
<input type="checkbox"/>	COMMERCIAL

New Construction Service Application

Deposit Amount Required _____ Connection Fee **\$125.00**

Deposit amount to be determined.

IF THIS APPLICATION IS NOT COMPLETED IN A HILCO OFFICE, THE APPLICATION MUST BE NOTARIZED BEFORE ELECTRIC SERVICE WILL BE ESTABLISHED

Service Address _____

Date Needed _____

City _____ State _____ Zip _____

Directions, Subdivision or Special Instructions _____

Will your service be: Overhead _____ Underground _____

Applicant Information

Co-Applicant Information

Name or Business Name _____
 Telephone# _____
 Cell Phone _____
 SSN# or Federal Tax ID _____
 Date of Birth _____
 Driver's License _____
 Place of Employment _____
 Business Phone _____
 Business Fax _____
 Email Address _____

Member Mailing Address _____

(if different then Service Address)

City _____ State _____ Zip _____

By signing the application, I/we accept membership in HILCO Electric Cooperative, Inc.; authorize HILCO Electric Cooperative, Inc. to utilize third parties acquire my/our consumer information, consumer reports, and credit worthiness scores for the purpose of determining credit worthiness; and agree to adhere to the bylaws and Tariff of the cooperative. I/We understand and agree that any credit granted shall be paid promptly in accordance with terms and agreements and that late fees may apply if payment is not received. I/We further understand and agree that in event of default, I/we will be responsible for reasonable collection charges, court costs, and/or attorney fees incurred to collect the debt.

Applicant's Signature _____

_____ Date

Co-Applicant's Signature _____

_____ Date

Would You like to Participate in Operation Round Up _____ Yes _____ No

Every month, the additional pennies, nickels and dimes are added to a special fund to help organizations in our service area. A committee, representing all seven districts in HILCO's service area, will be responsible for deciding where the funds are to be allocated. Once the committee allocates the funds, selected community and charitable organizations will receive the proceeds. We will keep you informed on how much is collected and where the funds are distributed.

State of _____
 County of _____

On this day _____, before me personally appeared _____ &
 who certifies that he/she has the authority to enter into an agreement between HILCO Electric Cooperative, Inc. and
 (company name).

Affix Seal Below

 Notary Public Printed Name

 Signature of Notary Public

* All applicable areas must be completed. Incomplete applications will be returned.

If "Date Needed" section is not completed, the new service/work order will be scheduled per HILCO's routine course of business.



HILCO Electric Cooperative, Inc. Electric Service Agreement

The undersigned (the "Member") agrees to purchase electric service from HILCO Electric Cooperative, Inc. (the "Cooperative") upon the following terms and conditions:

1. **Service.** Cooperative agrees to use reasonable diligence to provide electric utility service to a point of delivery at Member's service location. The electric service contracted for herein is to be provided and taken in accordance of this Agreement and the Cooperative's tariff. SAID TARIFF IS A PART OF THIS AGREEMENT TO THE SAME EXTENT AS IF FULLY SET OUT HEARIN AND IS ON FILE AND AVAILABLE AT THE COOPERATIVE'S OFFICES IN ITASCA, TEXAS.
2. **Payment.** Member agrees to purchase and pay for electric service in accordance with Cooperative's tariff. Periodically, Cooperative will render to Member a statement of services rendered. Member agrees to pay the total amount shown on such statement within sixteen (16) days from its date. Payment shall be made to Cooperative at its office.
3. **Term.** This Electric Service Agreement shall continue in force for an initial term of 5 years from the date service is made available, by the Cooperative to the Member. After this term, either party giving notice may terminate this agreement.
4. **Breach.** Upon failure to make payment or perform any obligation under this Agreement the Cooperative shall have the right to discontinue service as well as such remedies as may be provided by law. The Cooperative's LIABILITY is LIMITED as provided in its Tariff.
5. **Cooperative Line Extension Agreement.** Line extensions to Members are given an allowance in aid to construction. The Member must understand that they are given one year from the time the line is constructed to become a residential, non-residential, or commercial type service and meet the load requirements that has been provided to the Cooperative. In the event this does not occur the allowance will not be given and the Member will be expected to reimburse, the Cooperative, the full amount that was allotted. Your signature on the line below is acknowledgement that you understand the provision of this agreement. The attached load requirement form must be completed with the Member's / Representative's signature as acknowledgement of the allotted allowance, type of service requested, and load requirements.
6. **Lock on Gate.** Member allows Cooperative access to Member's property for electrical purposes. If a gate is now or at any time installed on the property the Member realizes that Cooperative will place a company lock on the chain for access.
7. **Member's Installation.** Member warrants that his or her installation (including all conductors, switches, equipment, wiring, and protective devices of any kind) is constructed and will be maintained in accordance with the National Electrical Safety Code of the American Standards Association as well as applicable laws or ordinances. Member understands that electrical conducted through the Cooperative's facilities may be dangerous and agrees that Member shall not permit any person on Member's premises to contact or come in close proximity to Cooperative's facilities.
8. **Entire Agreement.** This agreement constitutes the entire agreement between the parties and supercedes all prior agreements between Member and Cooperative for the service herein described. Member agrees the Cooperative its agents and employees, have made no representations, promises, or any inducements, written or verbal, which are not contained herein.
9. **Assignment of Capital Credits.** Member hereby assigns and transfers to the Cooperative the total book value of capital credits in Member's account which are available for retirement and agrees said amount shall become due and payable to the Cooperative one year after it has made a bona fide attempt to pay said amount and has not succeeded in doing so.

Sign: Member / Representative

Print: Member / Representative

Date

HILCO Electric Cooperative Representative

Date

(Below for Office Use Only)

Member : _____

Job Estimate: _____

Service Address : _____

Allowance : _____

W.O. # : _____

Aid to Construction : _____



HILCO Electric Cooperative, Inc Residential Load Requirement Form

PROJECT (ELECTRICAL WORK SITE)

Name: _____ Contact Person: _____

Service Address: _____ City: _____ State: _____ Zip Code: _____

Telephone: _____ Mobile: _____ Fax: _____

Email Address: _____

ELECTRICIAN

Name/Company: _____

Telephone: _____ Mobile: _____ Fax: _____

Email Address: _____

SERVICE REQUESTED

Type of Structure: Residential Non-Residential

** Commercial and / or Three-Phase need to use the "Commercial Load Requirement Form" **

Service Type: Overhead Service Underground Service

Entrance Conductors: _____ Size _____ Type _____ Number of Conductors

Meter Base Size: 100 Amp Base 200 Amp Base 320 Amp Base

Note: All services require a main disconnect within 8 circuit feet of the meter base location. All services rated above a 320 amp meter base will be required to have an outside main disconnect.

LOAD DATA (Please check the box that applies. If electric, then list the kW load)

Total Square Footage _____	Comments or Additional Info: _____
Square Footage with HVAC _____ (Square footage that is heated and cooled)	_____
HVAC "Heat" <input type="checkbox"/> Electric _____ kW or _____ Tons <input type="checkbox"/> Gas	_____
HVAC "A/C" <input type="checkbox"/> Electric _____ kW or _____ Tons	_____
Electric Water Heater <input type="checkbox"/> Electric _____ kW <input type="checkbox"/> Gas	_____
Tankless Water Heater <input type="checkbox"/> Electric _____ kW <input type="checkbox"/> Gas	_____
General / Misc. _____ kW	_____
Pool/Hot Tub Heater and Pumps <input type="checkbox"/> Electric _____ kW and _____ HP <input type="checkbox"/> Gas	_____
Fireplace <input type="checkbox"/> Electric <input type="checkbox"/> Gas	_____
Cooktop/Oven <input type="checkbox"/> Electric <input type="checkbox"/> Gas	_____

Load data must be completed as much as possible. Cost of changes, due to inadequate or inaccurate information will be borne by the Member/Representative.

SIGNATURE: _____ **DATE:** _____

Account Number:

HILCO Electric Cooperative, Inc.
A Texas Non-Profit, member-Owned Electric Cooperative

PERMISSION and WAIVER of LIABILITY

“Owner”: means that _____, the undersigned property owner, tenant, officer of corporate property owner, official representative or officer of civic or church group, or individual, whom has authority to grant permission and release liability regarding the property, including owner’s family, employees, agents, invitees, tenant’s personal representatives, or assigns.

“Property”: means that the property located in _____ County, Texas, Located at the address of

Address or Location: _____

“Work”: means to install and/or maintain electric power to the property or adjoining property. The employees of HILCO Electric, including its contractors, must enter the property owned, or in possession of, the owner to do the following work with the following circumstances:

- HILCO Electric will not be held liable for any damage to the property.
- HILCO Electric will not be responsible to replace or repair any issues that are a result of the work. Examples being, but not limited to, the repairing of driveways, dirt work, removal of debris, repairing of ruts, replacement of grass, sod and/or vegetation, etc.
- All underground facilities will need to be exposed or located, prior to construction, where the electric work intersects them. Underground facilities include, but are not limited to, water lines, owner’s electric lines, sewer and lateral lines, septic tanks, water sprinkler lines, etc.
 - **Any underground facilities not exposed or located, by the owner, could be damaged.**
 - **If the owner cannot expose or locate the underground facilities on the property, then the owner here by gives HILCO Electric, by signing below, permission to proceed by potentially damaging these facilities under these circumstances with the express understanding that any damage done to the property will be repaired at the owner’s expense.**
- Prior to construction, the path of the electric work must be clear of any obstructions.
- All work schedules are dependent upon weather and ground conditions.
- Underground trenching spoil will be mounded over the trench when it is covered. This method is used to avoid the trench from caving in by allowing proper settling.

“Owner” and HILCO Electric Cooperative, Inc. agree as follows regarding the property stated in this form above.

Owner states that:

- (1) The property is owned, or in the possession and control of the owner, who has the AUTHORITY to make this agreement:
- (2) Owner has the authority to grant HILCO Electric and here by grants HILCO Electric permission to enter, or cross the property and perform the scope of work, and
- (3) Owner WAIVES any right to any causes of action against HILCO Electric for direct or consequential damages to owner or owner’s property that might occur during the work.

(Signature of property owner or legal representative)

(Date)



EASEMENT INSTRUCTIONS

To help guide you through the process of completing this easement properly. Please find the attached electric easement and follow the instructions below. Blank spaces, on the easement form, are referenced in this guide by number. **Please use blue ink when completing this form.**

The Grantor(s) must fill out the entire easement form with blue ink and sign in front of a Notary Public.

Completed easements must be returned to HILCO Electric Cooperative, Inc. prior to construction. Failure to do so will delay the timely installation of your electric service.

***** HILCO Electric Cooperative, Inc. requires that a copy of the property or warranty deed be submitted along with this electric easement. *****

Page 1 of 2

Blank #1 (Grantor) : Fill in the name of the property owner(s). All persons shown on the property deed must be listed as the Grantor(s). If the property is owned by a corporation, then the corporation's name must be inserted here and the person signing on behalf of the corporation must be an authorized representative with legal authority.

Blank #2 (Address of Property) : Use the blank area to list the address, if available.

Blank #3 (Legal Description of Property) : This information can be found on the property or warranty deed. Fill in this area with the legal description of the property as it is described. The legal description is usually the first paragraph on the deed that includes the abstract, survey, acreage, lot, block or subdivision description of the land. Simply writing "See Attached" here or adding any referenced Exhibits will not be accepted.

Blank # 4 through #10 (Filed and Stamped in the Public Records) : Blank #4 needs to be filled in with the name of the County where the property is located. Blank #5 through #10 needs to be filled in with the Deed Number, the Volume Number, the Page Number, and the Date of which the property was filed and stamped in the Public Records Department. This information can be found on the property or warranty deed and must be from the current owner(s) signing the electric easement.

Page 2 of 2

Blank #1 through #3 (Date) : Enter the date the Grantor(s) are signing this easement in the space provided.

Blank #4 through #5 (Grantor #1 Signature) : Sign and print on the indicated lines. If more than one owner is listed on the deed of the property, then multiple grantors will need to sign.

Blank #6 (County of Notary Public) : The Notary Public should legibly fill in the county where they are empowered to act.

Blank #7 through #9 (Date & Grantor Printed Name) : The Notary Public should legibly fill in all blanks. Enter date in the space provided. Print Grantor name on the indicated lines provided.

Blank #10 (Notary Public Signature) : Should be signed by the Notary Public

Blank #11 (Notary Public Expiration) : Fill in the expiration date of the Notary's commission.

Blank #13 through #21 (Grantor #2 Signature & Notary Public) : If applicable, this section is the same as above, if there is a second Grantor.

Blank #22 through #35 (For Corporations) : Only authorized representatives with legal authority shall sign on the indicated lines. The Notary Public should legibly fill in the provided notary section.

HILCO ELECTRIC COOPERATIVE
UTILITY EASEMENT AND COVENANT OF ACCESS

Grantors: _____

Grantee: HILCO ELECTRIC COOPERATIVE, INC., its successors and assigns (hereinafter called the "Cooperative")

Consideration: for good and valuable consideration including the approval and execution of an Electric Service Agreement.

Property of Grantor: **Address** (if available): _____

Legal Description of Property: _____

as described in that document filed in the Public Records of

_____ **County, Texas, in Deed Number:** _____ **Volume Number:** _____

Page Number: _____ **on the** _____ **day of** _____, **20** _____.

Easement size: The easement rights herein described shall be no broader than reasonably necessary to provide electric and other utility service. The width of the easement shall be 20 feet, 1/2 of such distance on either side of the Cooperative's lines, poles, or other facilities. The height of the easement shall be from 15 feet beneath the surface of the ground to a height of 70 feet above the ground.

The right-of-way, easement, rights and privileges herein granted shall be used:

- (1) to provide electric utility service, including placing, constructing, operating, repairing, inspecting, rebuilding, replacing, removing, relocating, upgrading, maintaining overhead or underground electric distribution facilities, lines, or cables, by one or more circuits, with necessary foundations, footings, or equipment; extending lines for other service to other property and services beyond the Property; and carrying telephone or cable television wires of the Cooperative or any lessee thereof, which right will continue if the line is deactivated;
- (2) prohibit the construction of any structures (except ordinary fencing) upon, over, under, or within ten lateral feet from any electric line or within such proximity to an above-ground electric facility that such construction would endanger the operation or prevent the maintenance of the line or system, except upon the prior agreement thereto by the Cooperative;
- (3) install at angle points guy wires, anchors, and stub poles outside the designated right of way strip;
- (4) clear that land outside the right-of-way strip within ten feet of the service door of any transformer or cabinet located within the right-of-way strip and to keep the area within ten feet of the door clear of trees, structures or other obstructions;
- (5) for underground lines, to construct by digging, trenching, and by other reasonable means, maintain, operate, relocate and replace underground electric facilities, lines, conduits with other necessary apparatus and appliances, either above ground or below ground, to include transformers and service connections, for the purposes of transporting electricity and for the communications purposes of Grantee and its licensees;
- (6) clear the right-of-way of all obstructions, including but not limited to mechanical or chemical means or otherwise;
- (7) cut, trim and chemically control trees and shrubbery to the extent necessary to lay cables and to keep and maintain a right-of-way clear of all structures (except ordinary fences), trees, stumps, roots, shrubbery and undergrowth along said electric lines, facilities, or structures for a space of 10 feet on each side of the line;
- (8) cut down all
 - (a) dead, weak or dangerous trees outside of the right-of-way which, in the opinion of the Cooperative representatives, constitute a hazard to or may endanger the safety and proper operation of or maintenance of said lines, facilities, or structures, a danger tree being any tree that is tall enough to strike wires in falling or trees of any species that Grantee determines will grow at maturity to a height that will endanger the property maintenance and operation of said lines, and
 - (b) limbs outside of the right-of-way strip which, in the opinion of the Grantee, might interfere with or fall upon the electric or communications facilities within the right-of-way strip; and to install guy wire and anchors extending beyond the right-of-way strip when determined necessary by the Grantee;

(9) jointly use or occupy the line or system with any other person, association or corporation for electrification or telephone purposes and to add cable television lines, coaxial cable, or fiber-optic transmission lines and for similar or compatible uses of existing electric line facilities and easements;

(10) read any meter or performing any act related to the provision of utility service; and

(11) use as much of the surface of the Property of Grantor that is reasonably necessary to construct and maintain the facilities within the right-of-way granted. All trees which the Cooperative is authorized to cut by this agreement shall be the property of the Cooperative.

The easement, right, and privilege herein granted shall be perpetual, appurtenant to the land, and shall inure to the benefit of the Cooperative, its successors and assigns. Grantor represents that Grantor is the owner of the above-described tract of land and binds himself/herself/itself, his/her/its heirs, successors, assigns, and legal representatives to warrant and forever defend the easement and rights described herein to the Cooperative, its successors and assigns.

Grantor further covenants that Grantor, his/her/its heirs, successors and assigns shall facilitate and assist Cooperative personnel in exercising their rights and privileges herein described at all reasonable times and shall not build, construct or cause to be erected any building or other structure that may interfere with provision of electric service or the exercise of the rights granted to the Cooperative herein.

Signed in front of a Notary Public this _____ day of _____, 20_____.

STATE OF TEXAS
COUNTY OF _____

Grantor #1 [Signature]

This instrument was acknowledged before me on the _____ day of _____, 20____ by _____ **[Grantor #1].**

[Signature] Notary Public, State of Texas My Commission Expires: _____ / _____ / _____

Grantor #1 [Print]

N
O S
T E
A A
R L
Y

STATE OF TEXAS
COUNTY OF _____

Grantor #2 [Signature]

This instrument was acknowledged before me on the _____ day of _____, 20____ by _____ **[Grantor #2].**

[Signature] Notary Public, State of Texas My Commission Expires: _____ / _____ / _____

Grantor #2 [Print]

N
O S
T E
A A
R L
Y

If Corporation or Other Legal Entity:

STATE OF TEXAS
COUNTY OF _____

Exact Legal Name of Entity

This instrument was acknowledged before me on the _____ day of _____, 20____ by _____ **[Name of Officer], _____ [Title of Officer] of**

By: _____
[Signature] Authorized Officer/Representative

Corporation/Entity], in _____ [State of Incorporation], in
behalf of said corporation.

[Print]

[Signature] Notary Public, State of Texas My Commission Expires: _____ / _____ / _____

[Title]

N
O S
T E
A A
R L
Y



METER LOOP

AND

WIRING SPECIFICATIONS

HILCO ELECTRIC COOPERATIVE, INC.
METER LOOP AND WIRING SPECIFICATIONS

** The following meter loop and wiring specifications are intended for residential and **
small non-residential services. Where service requirements exceed single phase 120/240
voltage and/or 320 amps, please contact HILCO Electric Cooperative for any adjustments and
additional requirements.

****WARNING****

PLEASE CALL FOR UTILITY LOCATES BEFORE DIGGING

AT 1-800-DIGTESS or 811

HILCO Electric Cooperative shall require that the following conditions be met before electric service will be provided:

1. The consumer is responsible for installing and maintaining the electrical facilities in accordance with HILCO requirements.
2. The consumer may not contact, attach or utilize HILCO's electric distribution facilities.
3. HILCO reserves the right to approve a consumer's complete electric system and to determine that all conditions of code, safety and the design of the facilities being served have no detrimental effects upon the utility service. **Where HILCO specifications exceed code they shall take precedence.**
4. Consumers will furnish the meter base, meter loop, and service entrance facilities. Poles and/or any material used for meter loops shall be the consumer's responsibility.
5. Poles and/or any material used for meter loops shall be made of sound material and appropriately treated to resist degradation from the environment. HILCO will not connect service to any type of pole that has been spliced or pieced together. (Refer to the appropriate specification for installation and size requirements.)
6. Temporary meter loops are the consumer's responsibility and are meant to be temporary installations used during construction. Temporary meter loops shall be a minimum distance from HILCO's overhead facilities and shall not exceed ninety feet (90'). For underground installations, temporary poles shall not exceed ten feet (10') from HILCO's underground facilities.
7. The consumer shall install the appropriate contact apparatus to accept HILCO's electric service. All mast risers (through the roof) shall be 2" galvanized rigid metal conduit (as a minimum) and of sufficient strength to support the service drop conductors.
8. All service contacts shall not be less than thirteen (13') feet from final grade and all weather heads shall not be less than twelve and a half (12' 6") feet from final grade. **HILCO Electric enforces the National Electric Safety Code Section 23 Rule 232 and takes precedence over this rule to ensure that adequate clearances are met and maintained.**

9. The meter base shall normally be the socket type, shall be located outside of buildings, must be able to accept a padlock by HILCO and shall be accessible to HILCO employees at all times.
10. HILCO Electric's specifications do not allow "double lugging" or the installation of multiple conductors under one lug inside the meter base. Specific meter bases may accept multiple conductors, if it has the ability to exchange the lugs to accommodate and also if space permits within the meter base.
11. The meter loop will consist of three INSULATED COPPER or ALUMINUM wires, 100-amp capacity as a minimum for residential service and 60-amp capacity as a minimum for non-residential service. The neutral, as a minimum, can not be smaller than two sizes below the conductor size.
12. Wire size shall be based according to load, amp rating of main disconnect and rating of meter base. To ensure proper coordination, the amp rating of wire should be equal to or greater than the main disconnect and the main disconnect shall not exceed the amp rating of the meter base.
 - A. The main disconnect shall have a rating not less than the calculated load to be carried.
 - B. Every service shall have a main disconnect. The NEC Article 230.71, changed in 2020, and **does not** allow a maximum of six breakers to be grouped in the place of a main disconnect.
13. HILCO **will not** attach their electric service directly to any type of portable or mobile structure.
14. HILCO **will** attach their electric service directly to a manufactured home or structure, provided that any axles and tongue/hitches be removed, it is mounted on a permanent, poured-in-place, concrete foundation and/or piers.
15. Where service is supplied by more than one electric service to a single structure, a permanent plaque must be installed containing information describing all other electric services, their location and the area they serve.
16. The NEC, specifically Article 250, defines various types of grounding electrodes and methods for grounding. HILCO takes precedence over NEC and requires all ground rods to be driven at least 8 feet deep into the earth and shall be located outside the foundation and structure.
17. Service equipment disconnecting means or main breaker shall be provided and installed by the consumer. Its purpose shall be to provide disconnection of all conductors in a building or other structure from the service-entrance conductors. The NEC Code gives note, in Article 230.70, that the location of the disconnecting means shall be "readily accessible" and gives HILCO, as the electric provider, the authority to enforce this location.

- A. HILCO Electric takes precedence over this Article 230.70 and states that all service equipment disconnecting means shall be installed within a distance of eight circuit feet from the service entrance.
- B. If the distance of eight (8') circuit feet can not be met, then either an outside main disconnect needs to be installed or a readily accessible location needs to be used.

Allowable ampacities for residential dwellings and other non-residential applications. NEC Code gives note, in Article 310.12, that residential dwellings shall have a minimum 100 amp and all other non-residential, in Article 230.79 (D), shall have a minimum 60 amp utilizing the below wire ampacity tables:

Copper Wire (THW) Size and Ampacity	Residential		Non-Residential	
	NEC	Table 310.12 Residential Service Entrance	NEC	Table 310.16 Non-Residential Service Entrance
# 6		-		65 amps
# 4		100 amps		85 amps
# 3		110 amps		100 amps
# 2		125 amps		115 amps
# 1		150 amps		130 amps
# 1/0		175 amps		150 amps
# 2/0		200 amps		175 amps
# 3/0		225 amps		200 amps
# 4/0		250 amps		230 amps
# 250		300 amps		255 amps
# 300		-		285 amps
# 350		350 amps		310 amps
# 400		400 amps		335 amps

Aluminum or Copper-Clad Aluminum Wire (THW) Size and Ampacity	NEC	Table 310.12 Residential Service-Entrance	NEC	Table 310.16 Non-Residential Service Entrance
# 4		-		65 amps
# 3		-		75 amps
# 2		100 amps		90 amps
# 1		110 amps		100 amps
# 1/0		125 amps		120 amps
# 2/0		150 amps		135 amps
# 3/0		175 amps		155 amps
# 4/0		200 amps		180 amps
# 250		225 amps		205 amps
# 300		250 amps		230 amps
# 350		300 amps		250 amps
# 500		350 amps		270 amps
# 600		400 amps		310 amps

HILCO ELECTRIC COOPERATIVE, INC.
TEMPORARY METER INSTALLATION-OVERHEAD SERVICE

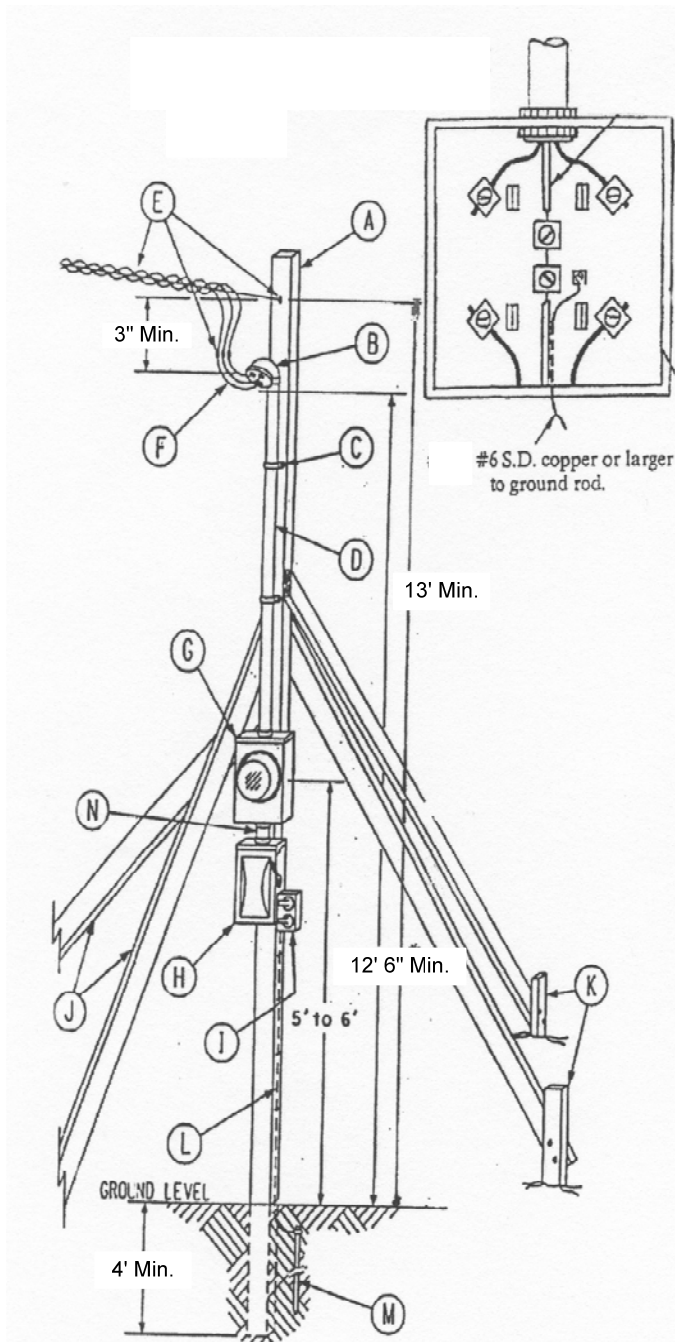

A - 4" X 4" X 17' WOODEN MAST MINIMUM.

B - DO NOT EXTEND WEATHERHEAD ABOVE TOP OF POLE. MUST BE MINIMUM 3" BELOW TOP OF POLE. (MINIMUM HEIGHT OF 12' 6" FROM FINAL GRADE)

C - METAL 2-HOLE CONDUIT STRAP SEPARATION SHALL BE NO GREATER THAN 30" WITH A MINIMUM OF 2 CONDUIT STRAPS.

D - SERVICE RISER SHALL BE FURNISHED AND INSTALLED BY CONSUMER. RISER SHALL BE GALVANIZED RIGID STEEL, I.M.C. OR SCH 80 ELECTRICAL PVC. (1 1/4" MIN)

E - SERVICE DROP CONDUCTORS, SERVICE ATTACHMENTS, AND CONNECTORS FURNISHED AND INSTALLED BY HILCO. (MINIMUM HEIGHT OF 13' FROM FINAL GRADE)

F - A MINIMUM OF 2' OF CONDUCTOR SHALL EXTEND FROM WEATHERHEAD TO FORM DRIP LOOP. CONSUMER SHALL MARK NEUTRAL WITH WHITE TAPE.

G - METER BASE FURNISHED, INSTALLED, AND WIRED BY CONSUMER. (MINIMUM 5' TO 6' FROM GRADE)

H - WEATHERPROOF BOX, WITH MAIN DISCONNECT. FURNISHED AND INSTALLED BY CONSUMER. (AMP RATING SHALL BE CONSISTANT WITH SERVICE CONDUCTOR AMPACITY)

I - ANY WEATHERPROOF RECEPTACLES SHALL HAVE GROUND FAULT PROTECTION.

J - 2" X 4" BRACES ATTACHED WITH LUG SCREWS OR 16 PENNY NAILS AT 90 FROM EACH OTHER. (FACED TOWARDS HILCO'S FACILITY)

K - 2" X 4" STAKES.

L - COPPER GROUNDING ELECTRODE CONDUCTOR SIZED AND INSTALLED BY CONSUMER ACCORDING TO HILCO REQUIREMENTS. (#6 SOFT DRAWN BARE OR STRANDED COPPER MINIMUM.)

M - APPROVED GROUNDING ELECTRODE AND CLAMP, FURNISHED AND INSTALLED BY CONSUMER. (GROUND ROD SHALL BE 5/8" X 8' COPPER OR GALVANIZED.)

N - NIPPLE RACEWAY TO METER SOCKET SHALL BE RIGID METAL, I.M.C. OR SCH 80 ELECTRICAL PVC.

**** Minimum 10' and Maximum 90' from **
HILCO's Facilities**

NOTE: CUSTOMER SHALL INSTALL AND MAINTAIN THIS FACILITY IN A SAFE CONDITION. IT CAN BE LEFT INTACT AND MOVED FROM JOB SITE TO JOB SITE. IT SHALL NOT BE MOVED WHILE ENERGIZED. INTENDED FOR TEMPORARY USE ONLY.

HILCO ELECTRIC COOPERATIVE, INC.
PERMANENT METER POLE

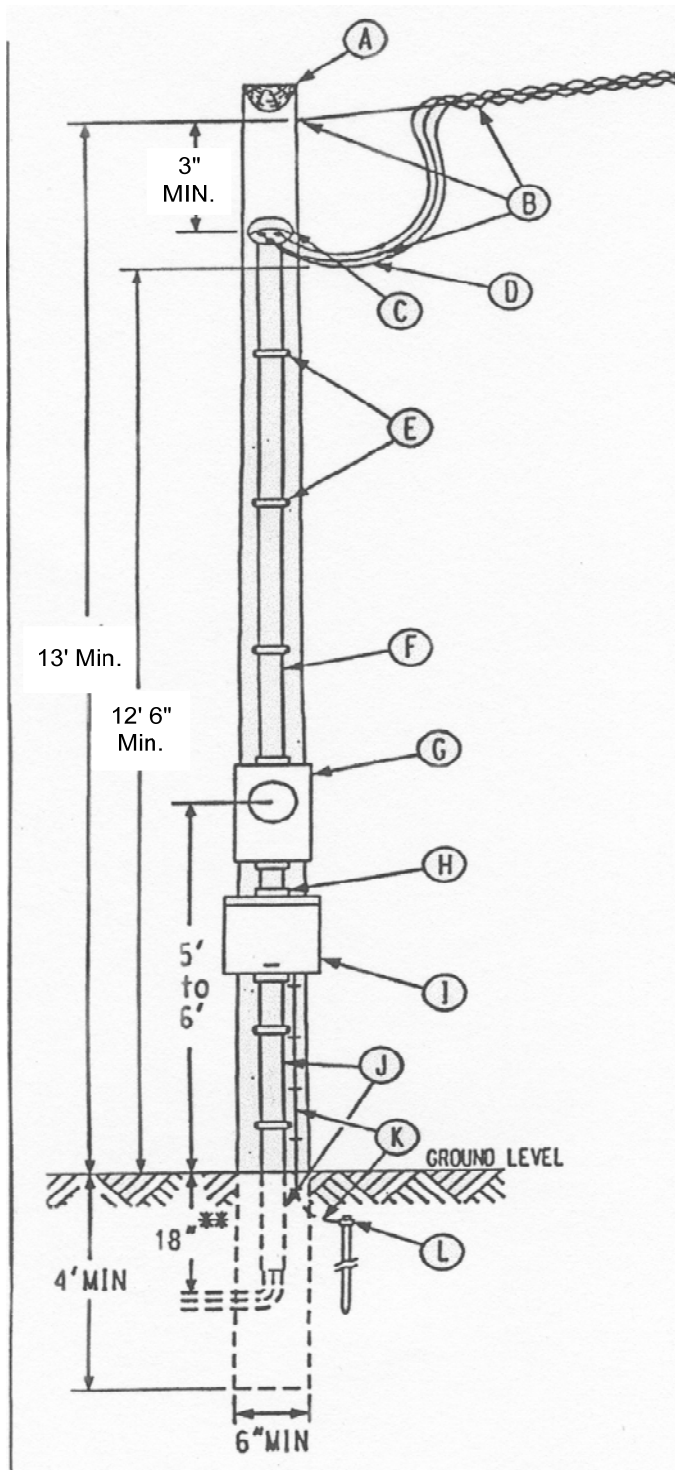

A – METER POLE INSTALLED BY CONSUMER. (POLE SHALL BE 6" X 17' MINIMUM)

B - SERVICE DROP CONDUCTORS. SERVICE ATTACHMENTS, AND CONNECTORS FURNISHED AND INSTALLED BY HILCO. (MINIMUM HEIGHT OF 13' FROM FINAL GRADE)

C - DO NOT EXTEND WEATHERHEAD ABOVE TOP OF POLE. MUST BE A MINIMUM 3" BELOW TOP OF POLE. (MINIMUM HEIGHT OF 12' 6" FROM FINAL GRADE)

D - A MINIMUM OF 2' OF CONDUCTOR SHALL EXTEND FROM WEATHERHEAD TO FORM DRIP LOOP. CONSUMER SHALL MARK NEUTRAL WITH WHITE TAPE.

E – METAL 2-HOLE CONDUIT STRAP SEPARATION SHALL BE NO GREATER THAN 30" WITH A MINIMUM OF 2 CONDUIT STRAPS.

F - SERVICE RISER WITH WEATHERHEAD, FURNISHED AND INSTALLED BY CONSUMER. SHALL BE GALVANIZED RIGID STEEL, I.M.C. OR SCH 80 ELECTRICAL PVC (1 ¼" MINIMUM).

G - METER BASE FURNISHED, INSTALLED, AND WIRED BY CONSUMER.

H - ALL CONDUIT NIPPLE RACEWAYS SHALL BE RIGID METAL, I.M.C. OR SCH 80 ELECTRICAL PVC.

I - WEATHERPROOF BOX, WITH MAIN DISCONNECT. FURNISHED AND INSTALLED BY CONSUMER. (AMP RATING SHALL BE CONSISTANT WITH SERVICE CONDUCTOR AMPACITY.)

J - SERVICE RACEWAY SHALL BE GALVANIZED RIGID STEEL CONDUIT, I.M.C. OR SCH 80 ELECTRICAL PVC. FURNISHED AND INSTALLED BY CONSUMER TO A MINIMUM DEPTH OF 18 INCHES BELOW GROUND LEVEL.

K - COPPER GROUNDING ELECTRODE CONDUCTOR FURNISHED AND INSTALLED BY CONSUMER. (#6 -SOFT DRAWN BARE OR STRANDED COPPER MINIMUM).

L - APPROVED GROUNDING ELECTRODE AND CLAMP, FURNISHED AND INSTALLED BY CONSUMER. (GROUNDING ROD SHALL BE 5/8" X 8' COPPER OR GALVANIZED).

**** Minimum 10' and Maximum 75' from **
HILCO's Facilities**

**HILCO ELECTRIC COOPERATIVE, INC.
OVERHEAD HOUSE METER SERVICE (UNDER EAVES)**

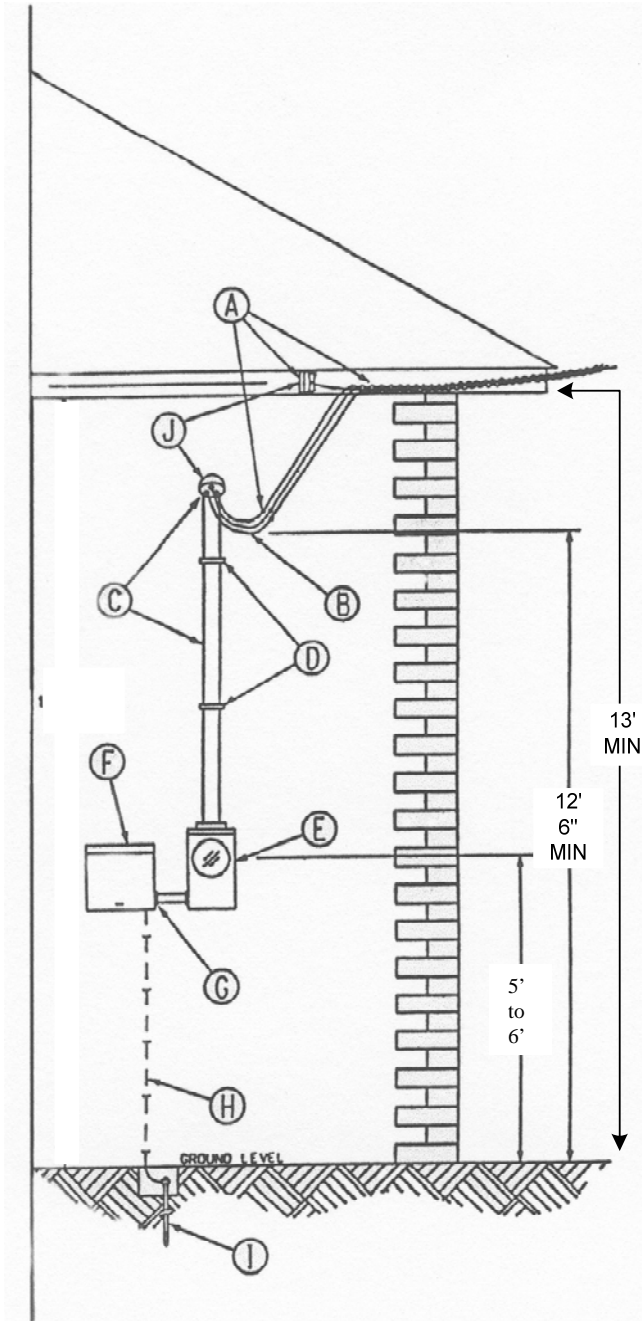

A - SERVICE DROP CONDUCTORS, SERVICE ATTACHMENT, AND CONNECTORS FURNISHED AND INSTALLED BY HILCO. (MINIMUM HEIGHT OF 13' FROM FINAL GRADE)

B - A MINIMUM OF 2' OF CONDUCTOR SHALL EXTEND FROM WEATHERHEAD TO FORM DRIP LOOP. CONSUMER SHALL MARK NEUTRAL WITH WHITE TAPE.

C - SERVICE RISER WITH WEATHERHEAD, FURNISHED AND INSTALLED BY CONSUMER, SHALL BE GALVANIZED RIGID STEEL, I.M.C. OR SCH 80 ELECTRICAL PVC. (1 ¼" MINIMUM) (MINIMUM HEIGHT OF 12' 6" FROM FINAL GRADE)

D - METAL 2-HOLE CONDUIT STRAP SEPARATION SHALL BE NO GREATER THAN 30" WITH A MINIMUM OF 2 CONDUIT STRAPS.

E - METER BASE FURNISHED, INSTALLED, AND WIRED BY CONSUMER.

F - WEATHERPROOF BOX, WITH MAIN DISCONNECT. FURNISHED AND INSTALLED BY CONSUMER. THE ENCLOSURE SHALL BE WITHIN 8 CIRCUIT FEET OF THE METER (AMP RATING SHALL BE CONSISTANT WITH SERVICE CONDUCTOR AMPACITY)

G - ALL CONDUIT NIPPLE RACEWAYS SHALL BE RIGID METAL, I.M.T. OR SCH 80 ELECTRICAL PVC.

H - COPPER GROUNDING ELECTRODE CONDUCTOR FURNISHED AND INSTALLED BY CONSUMER. (#6 SOFT DRAWN BARE OR STRANDED COPPER MINIMUM)

I - APPROVED GROUNDING ELECTRODE AND CLAMP, FURNISHED AND INSTALLED OUTSIDE THE STRUCTURE BY THE CONSUMER. (GROUND SHALL BE 5/8"X8' COPPER OR GALVANIZED.)

J - WEATHERHEAD SHALL BE WITHIN 24" OF POINT OF ATTACHMENT.

**HILCO ELECTRIC COOPERATIVE, INC.
OVERHEAD HOUSE METER SERVICE (ABOVE ROOF)**

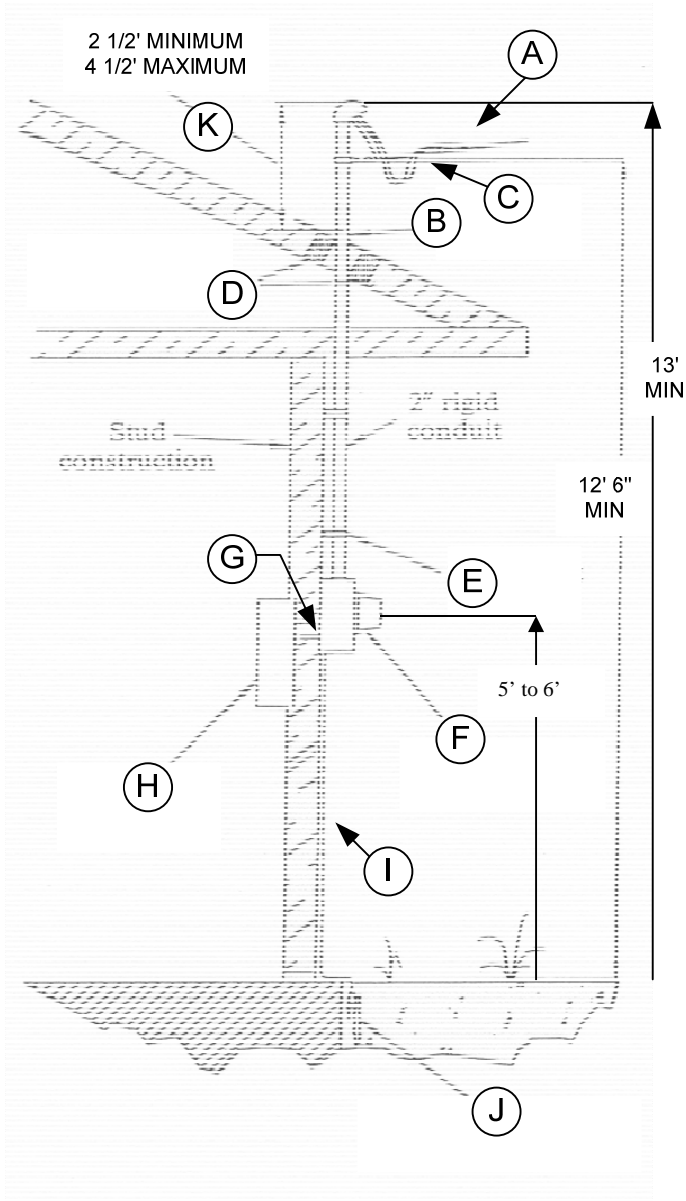

A - SERVICE DROP CONDUCTORS, SERVICE ATTACHMENT, AND CONNECTORS FURNISHED AND INSTALLED BY HILCO. (MINIMUM HEIGHT OF 12' 6" FROM FINAL GRADE)

B - GALVANIZED RIGID 2" CONDUIT AS A MINIMUM WITH WEATHERHEAD FURNISHED AND INSTALLED BY CONSUMER. ENTIRE RISER SHALL BE VISIBLE.

C - A MINIMUM OF 2' OF CONDUCTOR SHALL EXTEND FROM WEATHERHEAD TO FORM DRIP LOOP. CONSUMER SHALL MARK NEUTRAL WITH WHITE TAPE.

D - USE 2" X 4" BRACING BETWEEN RAFTERS, AS A MINIMUM, TO SUPPORT SERVICE RACEWAY.

E - SERVICE MAST TO BE SUPPORTED WITH METAL 2-HOLE CONDUIT STRAPS AT 30" SEPARATION MAXIMUM.

F - METER BASE FURNISHED, INSTALLED, AND WIRED BY CONSUMER.

G - ALL CONDUIT NIPPLE RACEWAYS SHALL BE RIGID METAL, I.M.C. OR SCH 80 ELECTRICAL PVC.

H - BREAKER BOX, WITH MAIN DISCONNECT. FURNISHED AND INSTALLED BY CONSUMER. THE ENCLOSURE SHALL BE WITHIN 8 CIRCUIT FEET OF THE METER. (AMP RATING SHALL BE CONSISTANT WITH SERVICE CONDUCTOR AMPACITY)

I - COPPER GROUNDING ELECTRODE CONDUCTOR FURNISHED AND INSTALLED BY CONSUMER. (#6 - SOFT DRAWN BARE OR STRANDED COPPER MINIMUM

J - APPROVED GROUNDING ELECTRODE AND CLAMP FURNISHED AND INSTALLED OUTSIDE THE STRUCTURE BY THE CONSUMER. (GROUND ROD SHALL BE 5/8" X 8'. COPPER OR GALVANIZED.)

K - CLEARANCE OF SERVICE CONDUCTOR ABOVE ROOF, SHALL BE A MINIMUM HEIGHT OF 18" AND A DISTANCE OF 4' FROM WITHIN THE EDGE OF THE ROOF. IF DISTANCE IS FURTHER THAN 4' FROM EDGE, THEN CLEARANCE HEIGHT OVER ROOF SHALL BE INCREASED TO 3' MINIMUM. (MINIMUM HEIGHT OF 13' FROM FINAL GRADE)

**** Recommended, any through the **
roof installation needs anchor supports
for riser and service conductors.**

**HILCO ELECTRIC COOPERATIVE, INC.
OVERHEAD HOUSE METER SERVICE (METAL STRUCTURE)**

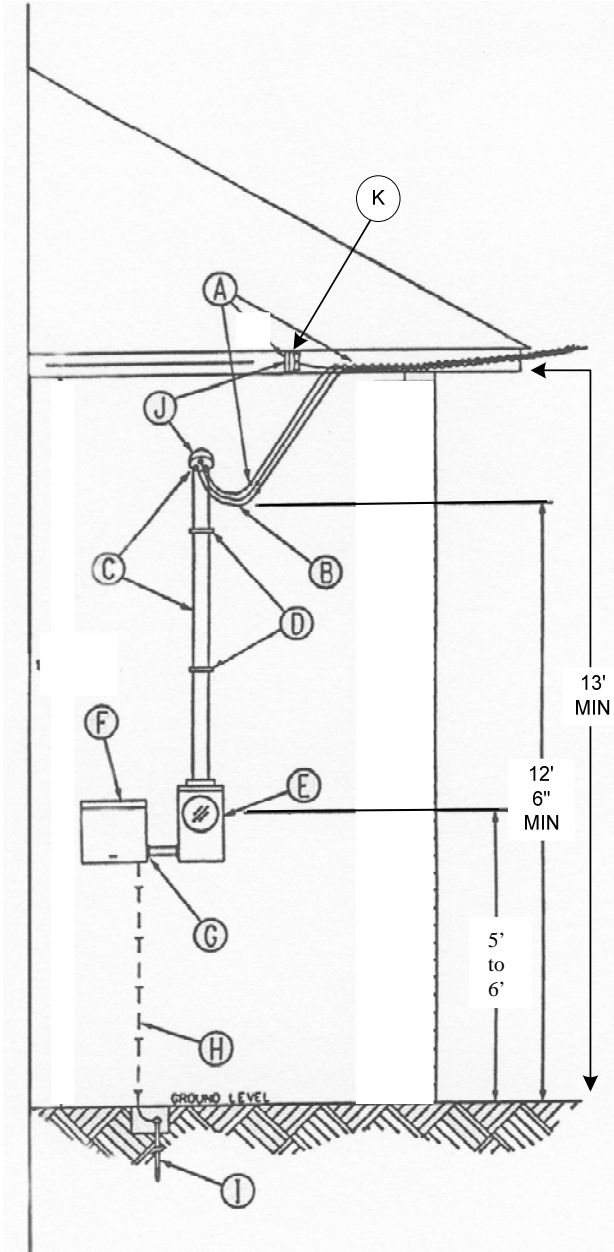

A - SERVICE DROP CONDUCTORS AND CONNECTORS FURNISHED AND INSTALLED BY HILCO. (CONSUMER WILL NEED TO INSTALL EYE BOLT FOR HILCO'S WIRE ATTACHMENT) (MINIMUM HEIGHT OF 13' FROM FINAL GRADE)

B - A MINIMUM OF 2' OF CONDUCTOR SHALL EXTEND FROM WEATHERHEAD TO FORM DRIP LOOP. CONSUMER SHALL MARK NEUTRAL WITH WHITE TAPE.

C - SERVICE RISER WITH WEATHERHEAD, FURNISHED AND INSTALLED BY CONSUMER, SHALL BE GALVANIZED RIGID STEEL, I.M.T. OR SCH 80 ELECTRICAL PVC. (1 1/4" MINIMUM) (MINIMUM HEIGHT OF 12' 6" FROM FINAL GRADE)

D - METAL 2-HOLE CONDUIT STRAP SEPARATION SHALL BE NO GREATER THAN 30" WITH A MINIMUM OF 2 CONDUIT STRAPS.

E - METER BASE FURNISHED, INSTALLED, AND WIRED BY CONSUMER.

F - WEATHERPROOF BOX, WITH MAIN DISCONNECT. FURNISHED AND INSTALLED BY CONSUMER. THE ENCLOSURE SHALL BE WITHIN 8 CIRCUIT FEET OF THE METER. (AMP RATING SHALL BE CONSISTANT WITH SERVICE CONDUCTOR AMPACITY)

G - ALL CONDUIT NIPPLE RACEWAYS SHALL BE RIGID METAL, I.M.T. OR SCH 80 ELECTRICAL PVC.

H - COPPER GROUNDING ELECTRODE CONDUCTOR FURNISHED AND INSTALLED BY CONSUMER. (#6 -SOFT DRAWN BARE OR STRANDED COPPER MINIMUM)

I - APPROVED GROUNDING ELECTRODE AND CLAMP, FURNISHED AND INSTALLED OUTSIDE THE STRUCTURE BY THE CONSUMER. (GROUND ROD SHALL BE 5/8" X 8' COPPER OR GALVANIZED.)

J - WEATHERHEAD SHALL BE WITHIN 24" OF POINT OF ATTACHMENT.

K - EYE BOLT FURNISHED AND INSTALLED BY CUSTOMER TO SUPPORT HILCO'S SERVICE WIRE.

HILCO ELECTRIC COOPERATIVE, INC.
TEMPORARY METER INSTALLATION-UNDERGROUND SERVICE

*** WARNING *** PLEASE CALL FOR UTILITY LOCATES BEFORE *** WARNING ***
DIGGING NEAR UNDERGROUND ELECTRIC FACILITIES
1 - 800 - DIGTESS

**** Service address must be marked on pole ****
**** Maximum 10' from HILCO's Facilities ****

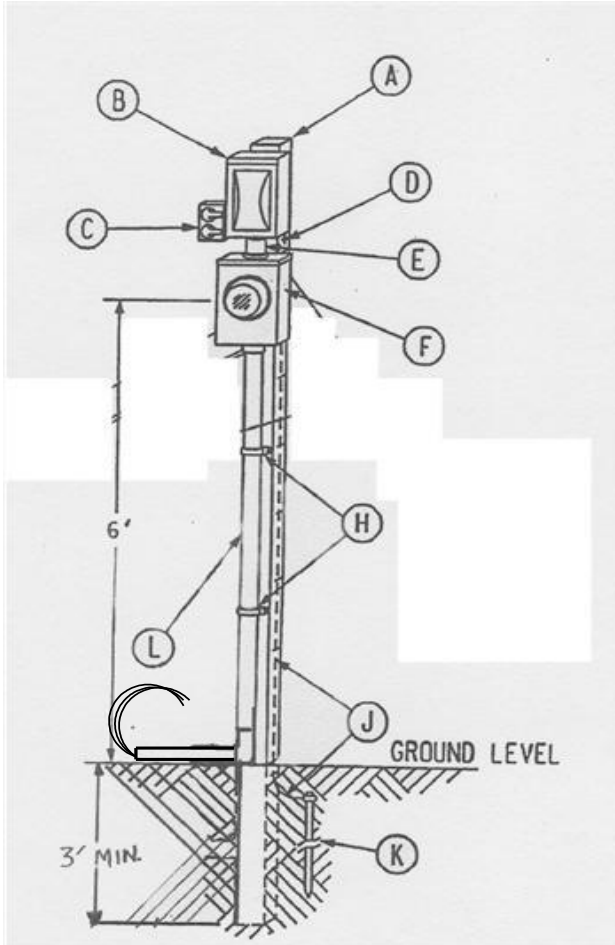

**WIRING DIAGRAM OF INSIDE
 UNDERGROUND TEMPORARY POLE
 METER BASE**

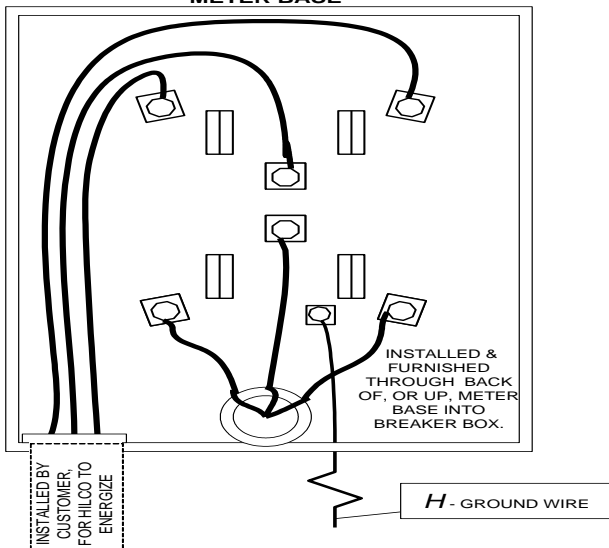

NOTE: CUSTOMER SHALL INSTALL AND MAINTAIN THIS FACILITY IN A SAFE CONDITION. IT CAN BE LEFT INTACT AND MOVED FROM JOB SITE TO JOB SITE. IT SHALL NOT BE MOVED WHILE ENERGIZED. INTENDED FOR TEMPORARY USE ONLY.

A - 4" X 4" X 10' WOODEN MAST MINIMUM

B - WEATHERPROOF BOX WITH MAIN DISCONNECT. FURNISHED AND INSTALLED BY CUSTOMER. (AMP RATING SHALL BE CONSISTANT WITH SERVICE CONDUCTOR AMPACITY)

C - ANY WEATHERPROOF RECEPTACLES SHALL HAVE GROUND FAULT PROTECTION.

D - GROUNDING ELECTRODE CONDUCTOR ENTERS AND IS CONNECTED TO BREAKER EQUIPMENT.

E - NIPPLE RACEWAY TO METER SOCKET SHALL BE RIGID METAL, I.M.C., OR SCH 80 ELECTRICAL PVC.

F - METER BASE FURNISHED, INSTALLED, AND WIRED BY CONSUMER.

H - METAL 2-HOLE CONDUIT STRAP SEPARATION SHALL BE NO GREATER THAN 30" WITH A MINIMUM OF 2 CONDUIT STRAPS.

J - COPPER GROUNDING ELECTRODE CONDUCTOR SIZED AND INSTALLED BY CONSUMER. ACCORDING TO HILCO REQUIREMENTS. (#6 SOFT DRAWN BARE OR STRANDED COPPER MINIMUM.)

K - APPROVED GROUNDING ELECTRODE AND CLAMP, FURNISHED AND INSTALLED BY CUSTOMER. (GROUNDING ROD SHALL BE 5/8" X 8' COPPER OR GALVANIZED.)

L - MINIMUM 1/4" SERVICE RACEWAY CONSTRUCTED OUT OF FLEX CONDUIT. CONDUIT AND WIRE SHALL HAVE A MINIMUM 15' OF EXTENSION, FROM THE BASE OF THE TEMPORARY POLE. THIS WILL BECOME THE "PIG TAIL" FOR HILCO TO ENERGIZE. (FURNISHED BY CONSUMER.)

**HILCO ELECTRIC COOPERATIVE, INC.
UNDERGROUND HOUSE METER SERVICE**

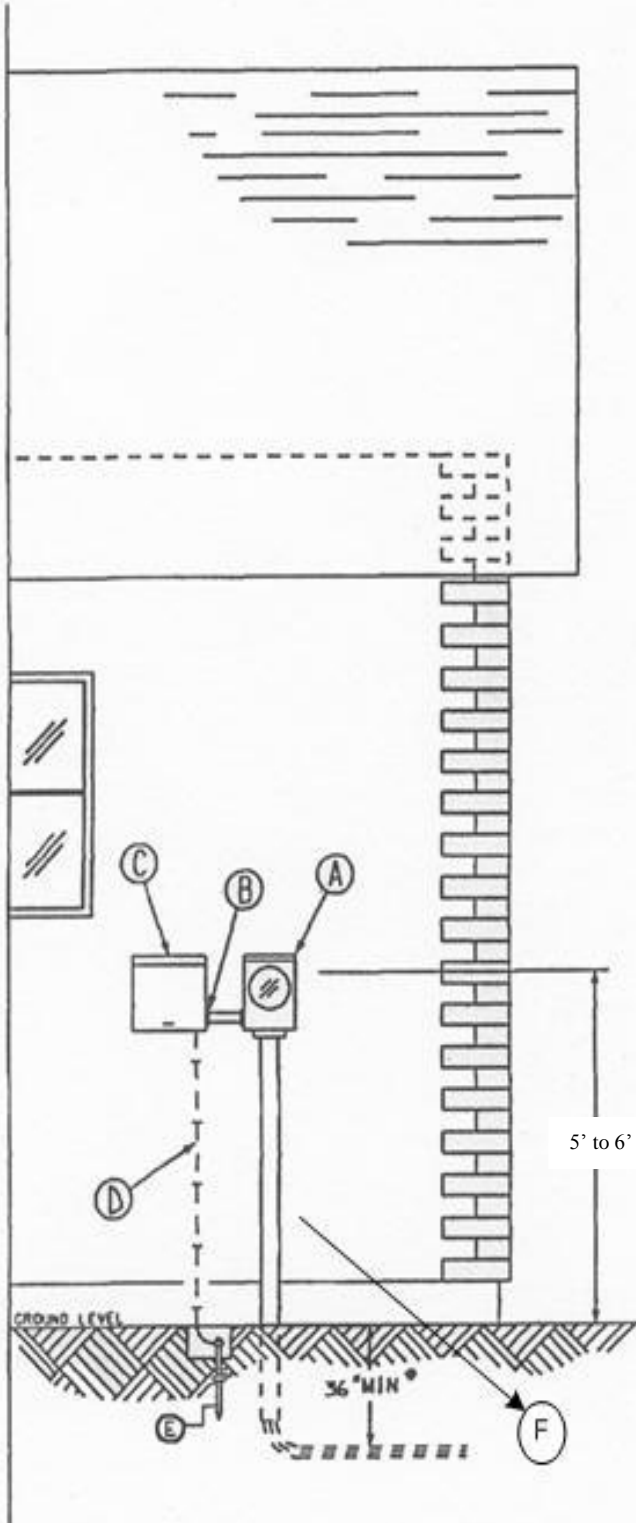

A - METER BASE FURNISHED, INSTALLED AND WIRED BY CONSUMER.

B - ALL CONDUIT NIPPLE RACEWAYS SHALL BE RIGID METAL, I.M.C. OR SCH 80 ELECTRICAL PVC.

C - WEATHERPROOF BOX, WITH MAIN DISCONNECT. FURNISHED AND INSTALLED BY! CONSUMER. THE ENCLOSURE SHALL BE WITHIN 8 CIRCUIT FEET OF THE METER (AMP RATING SHALL BE CONSISTANT WITH SERVICE CONDUCTOR AMPACITY)

D - COPPER GROUNDING ELECTRODE CONDUCTOR SIZED AND INSTALLED BY CONSUMER ACCORDING TO HILCO REQUIREMENTS. (#6 SOFT DRAWN BARE OR STRANDED COPPER MINIMUM.)

E - APPROVED GROUNDING ELECTRODE AND CLAMP, FURNISHED AND INSTALLED OUTSIDE THE STRUCTURE BY THE CONSUMER. (GROUND ROD SHALL BE 5/8" X 8' COPPER OR GALVANIZED.)

F - CONDUIT, WIRE, AND TRENCH INSTALLED BY HILCO ELECTRIC. CONDUIT RISER SHALL HAVE NO OBSTRUCTIONS OR BENDS GOING INTO THE METER BASE. ENTIRE CONDUIT RISER SHALL BE VISIBLE AND REMAIN ON THE OUTSIDE OF THE STRUCTURE.

**WIRING DIAGRAM OF INSIDE
 UNDERGROUND
 METER BASE**

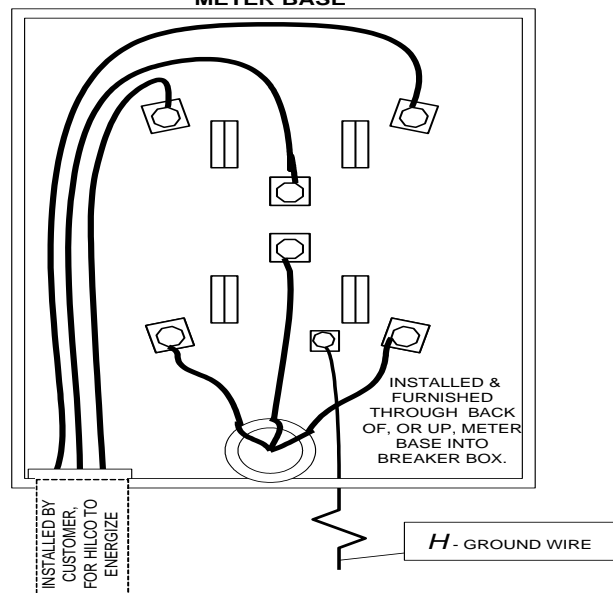

HILCO ELECTRIC COOPERATIVE, INC.

PERMANENT UNDERGROUND METER POLE (OPTION #1)

WIRING DIAGRAM OF INSIDE UNDERGROUND METER BASE

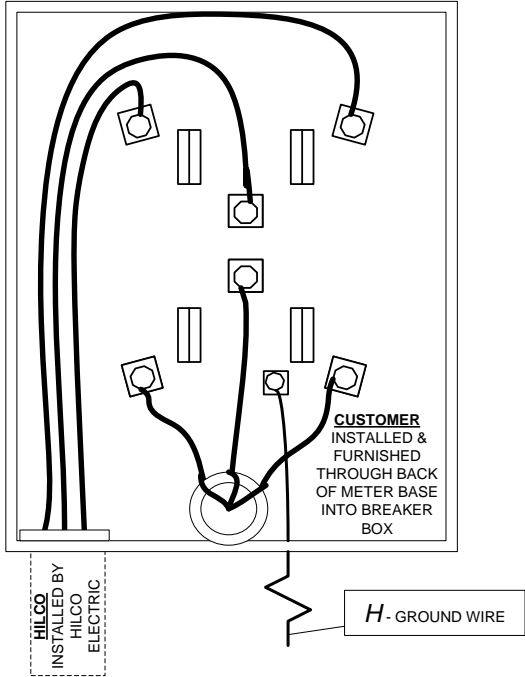

*** WARNING *** PLEASE CALL FOR UTILITY LOCATES BEFORE *** WARNING ***

DIGGING NEAR UNDERGROUND ELECTRIC FACILITY'S

1 - 800 - DIGTESS

A - 4" X 6" X 10' MAST MINIMUM MADE OF STABLE METAL MATERIAL OR TREATED WOOD.

B - WEATHERPROOF BOX, WITH MAIN DISCONNECT. FURNISHED AND INSTALLED BY CONSUMER. (AMP RATING SHALL BE CONSISTENT WITH SERVICE CONDUCTOR AMPACITY)

C - ELECTRIC METER, CONDUIT, WIRE, AND TRENCH INSTALLED BY HILCO ELECTRIC.

D - GROUNDING ELECTRODE CONDUCTOR ENTERS AND IS CONNECTED TO BREAKER EQUIPMENT.

E - NIPPLE RACEWAY TO METER SOCKET SHALL BE RIGID METAL, I.M.C. OR SCH 80 ELECTRICAL PVC AND SHALL BE INSTALLED THROUGH 4" X 6".

F - METER BASE FURNISHED, INSTALLED, AND WIRED BY CONSUMER.

G - METAL 2-HOLE CONDUIT STRAP SEPARATION SHALL BE NO GREATER THAN 30" WITH A MINIMUM OF 2 CONDUIT STRAPS.

H - COPPER GROUNDING ELECTRODE CONDUCTOR SIZED AND INSTALLED BY CONSUMER ACCORDING TO HILCO REQUIREMENTS. (#6 SOFT DRAWN BARE OR STRANDED COPPER MINIMUM.)

I - APPROVED GROUNDING ELECTRODE AND CLAMP, FURNISHED AND INSTALLED BY CONSUMER. (GROUNDING ROD SHALL BE 5/8" X 8' COPPER OR GALVANIZED.)

J - SERVICE RACEWAY SHALL BE GALVANIZED RIGID STEEL CONDUIT, I.M.C. OR SCH 80 ELECTRICAL PVC. FURNISHED AND INSTALLED BY CONSUMER TO A MINIMUM DEPTH OF 18 INCHES BELOW GROUND LEVEL.

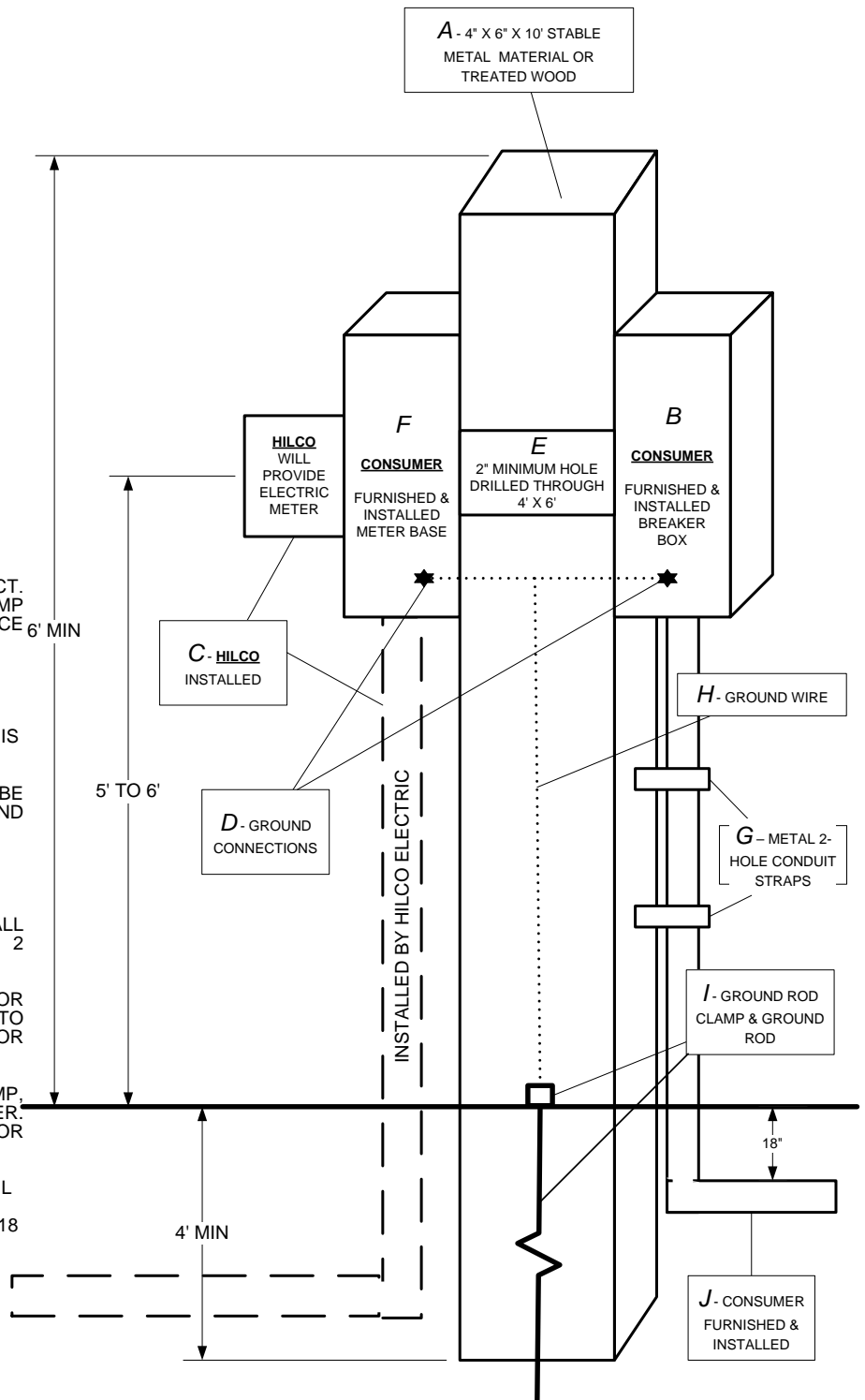

HILCO ELECTRIC COOPERATIVE, INC.

PERMANENT UNDERGROUND METER POLE (OPTION #2)

WIRING DIAGRAM OF INSIDE UNDERGROUND METER BASE

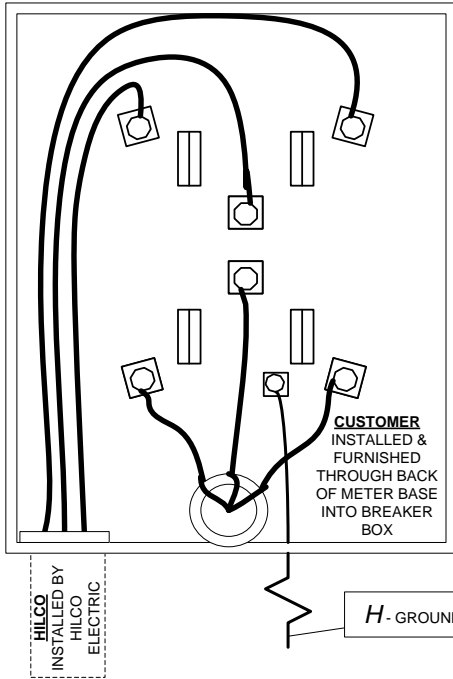

*** WARNING *** PLEASE CALL FOR UTILITY LOCATES BEFORE *** WARNING ***

DIGGING NEAR UNDERGROUND ELECTRIC FACILITY'S

1 - 800 - DIGTESS

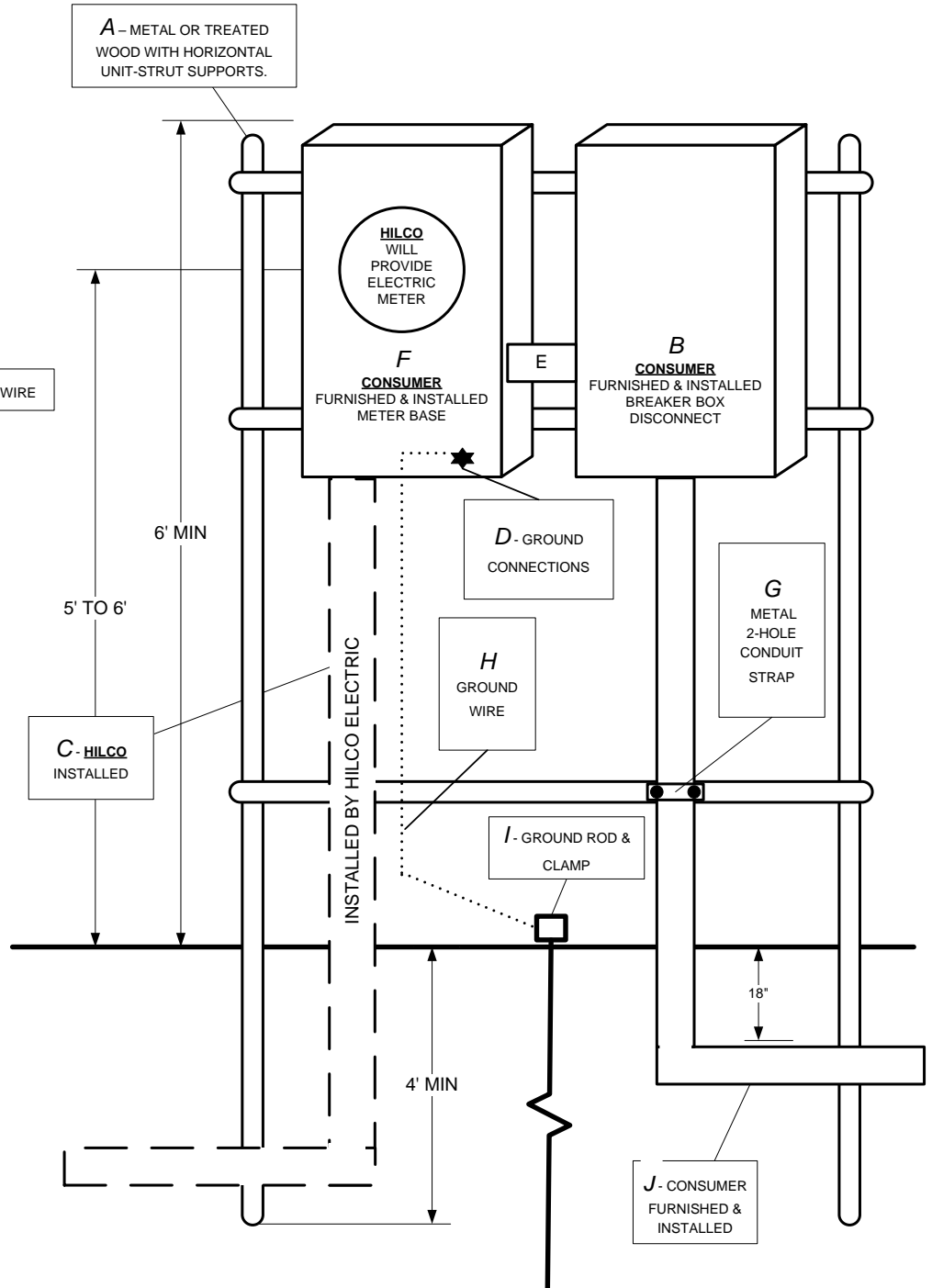

A - MADE OF STABLE METAL MATERIAL OR TREATED WOOD WITH HORIZONTAL UNIT-STRUT SUPPORTS.

B - WEATHERPROOF BOX, WITH MAIN DISCONNECT. FURNISHED AND INSTALLED BY THE CONSUMER. (AMP RATING SHALL BE CONSISTENT WITH SERVICE CONDUCTOR AMPACITY)

C - ELECTRIC METER, CONDUIT, WIRE, AND TRENCH INSTALLED BY HILCO ELECTRIC.

D - GROUNDING ELECTRODE CONDUCTOR ENTERS AND IS CONNECTED TO METER BASE.

E - NIPPLE RACEWAY TO METER SOCKET SHALL BE RIGID METAL, I.M.C. OR SCH 80 ELECTRICAL PVC.

F - METER BASE FURNISHED, INSTALLED, AND WIRED BY CONSUMER.

G - METAL 2-HOLE CONDUIT STRAP.

H - COPPER GROUNDING ELECTRODE CONDUCTOR SIZED AND INSTALLED BY CONSUMER ACCORDING TO HILCO REQUIREMENTS. (#6 SOFT DRAWN BARE OR STRANDED COPPER MINIMUM.)

I - APPROVED GROUNDING ELECTRODE AND CLAMP, FURNISHED AND INSTALLED BY CONSUMER. (GROUNDING ROD SHALL BE 5/8" X 8' COPPER OR GALVANIZED.)

J - SERVICE RACEWAY SHALL BE GALVANIZED RIGID STEEL CONDUIT, I.M.C. OR SCH 80 ELECTRICAL PVC. FURNISHED AND INSTALLED BY CONSUMER TO A MINIMUM DEPTH OF 18 INCHES BELOW GROUND LEVEL.